



**AIRFLOW AC**

# STATIONARY LOUVERS

**Airflow ac MIDDLE EAST FZE -LLC**

Email:-[airflowacme@gmail.com](mailto:airflowacme@gmail.com)

[www.airflowac.me](http://www.airflowac.me)

Tel:050-9293811

---



**SSL - 100**

Stationary Louver is a weather louver designed to provide air intake and air exhaust openings in building exterior walls to protect against direct ingress of rain. The blades are positioned on 98mm minimum centers up to 120mm maximum centers at 45 degree slope and has a high free area to provide minimum resistance to airflow.

**Construction Standards**

**Frame:**  
Gauge 16 (1.5mm thick) formed galvanized steel sheet.

**Blades:**  
Gauge 18 (1.2mm thick) formed galvanized steel sheet.

**Screen:**  
Galvanized steel bird screen 12 x 12 x 1mm fixed behind the blades . Please note that Pressure Drop Data is obtained from AMCA Test without bird screen. Pressure drop of bird screen is additive and to be caculated separately.

**Minimum Size:**  
200mm x 200mm (8in x 8in) - Neck Size.

**Maximum Size:**  
1250W x 2500H as single section (Neck Size).  
2500W x 2500H will be single module with 2 sections on horizontal blades.

Consult SAFID for multiple section assembly details.

**SSL - 110**  
General construction as type SSL - 100 but frame and blades are built from mill finish aluminum sheet.

**SSL - 120**  
General construction as type SSL - 100 but frame and blades are built from stainless steel Grade 304.

**Optional:** Frame and blades from stainless steel Grade 316 or 316L.

**Additional Options**

- \*Code Z: Painted to RAL (epoxy coated).
- \*Code I: Insect screen in galvanized steel 1 x 1 x 0.4mm.
- \*Code T: Bird screen in stainless steel 5 x 5 x 0.7mm.

Catalog ID: SSL - 100 March 25, 2015

SSL SERIES [SSL - 100, SSL - 110, SSL - 120]

**Air Performance**

**Pressure Drop**

**Exhaust Air Performance**

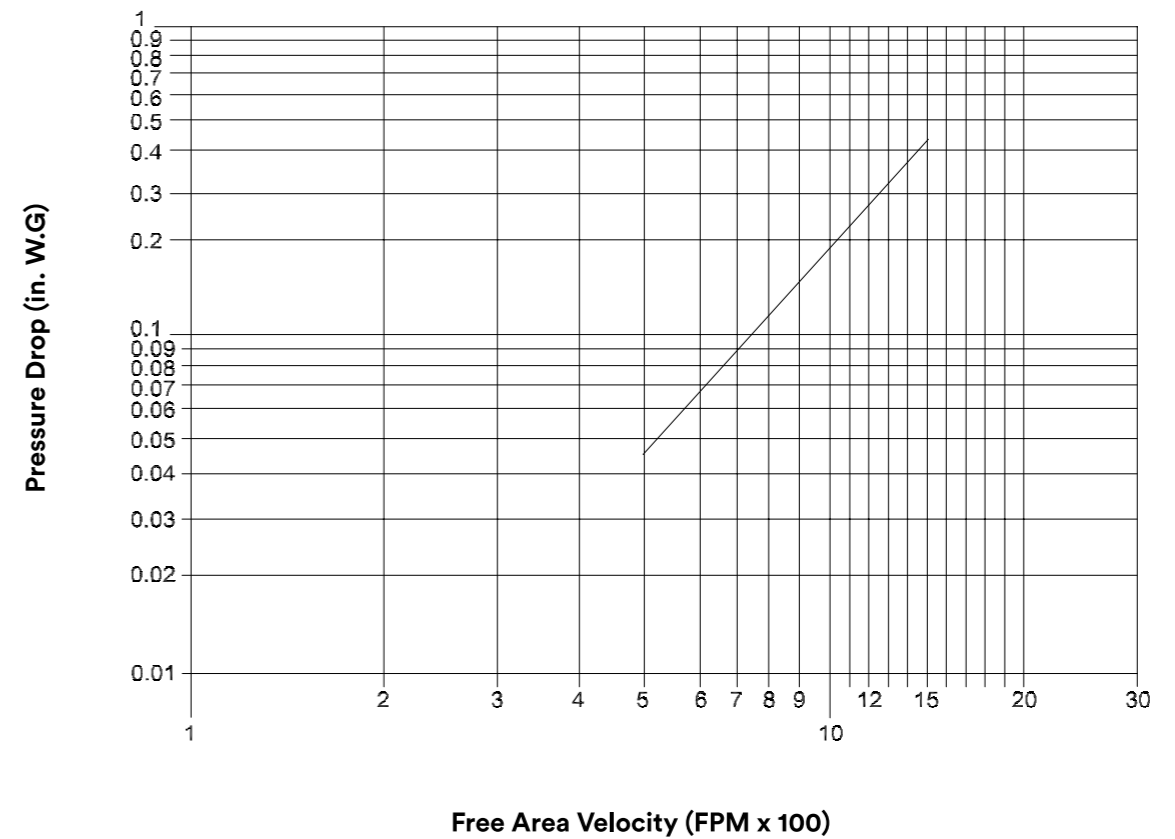

Data are corrected to standard air density.  
Test size: 48in. x 48 in.

Catalog ID: SSL - 100 January 26, 2014

STATIONARY LOUVER

SSL SERIES [SSL - 100, SSL - 110, SSL - 120]

Air Performance

Pressure Drop

Exhaust Air Performance

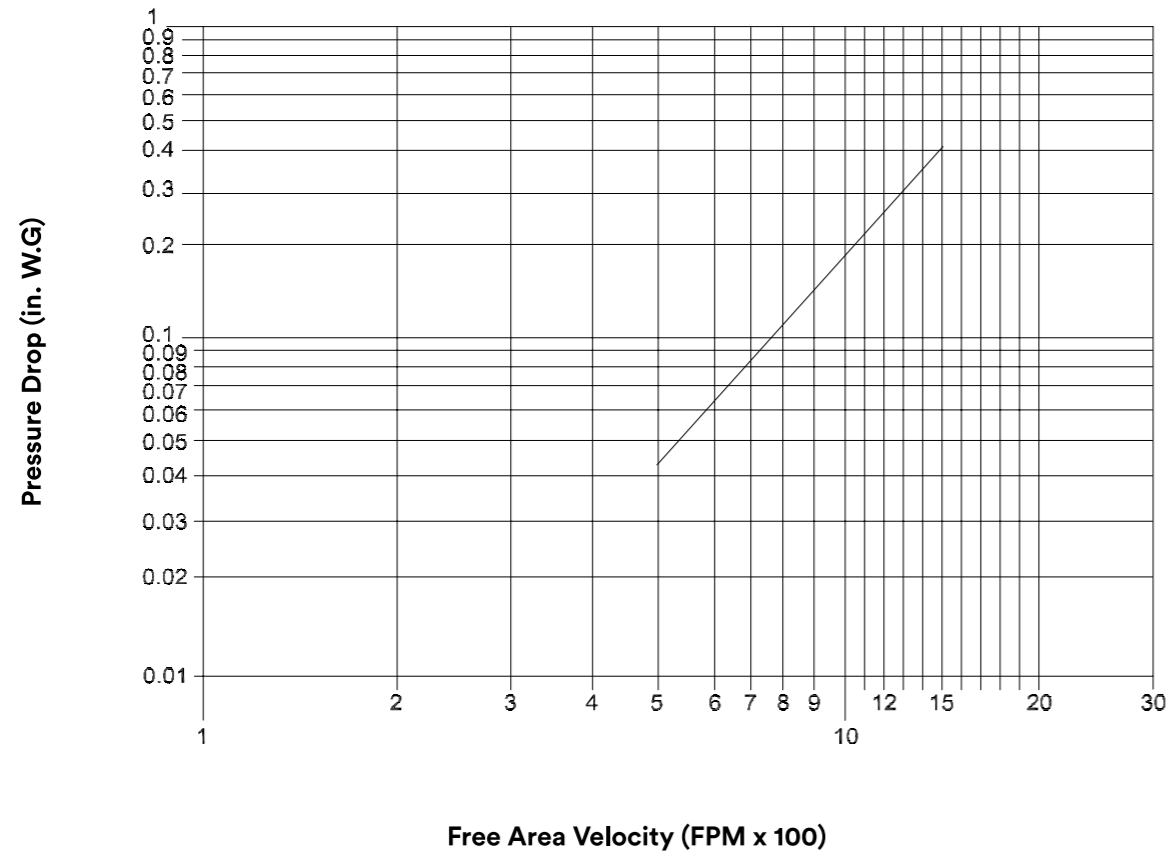

Data are corrected to standard air density.  
Test size: 48in. x 48 in.

STATIONARY LOUVER

SSL SERIES [SSL - 100, SSL - 110, SSL - 120]

Air Performance

Free Area Chart (Square Feet)

Outer Frame Size (W1 Inches)

	12	16	20	24	28	32	36	40	44	48	52	56	60	64	68	72	76	80	84	88	92	96	100	104
12	0.06	0.10	0.15	0.19	0.24	0.29	0.33	0.38	0.42	0.47	0.52	0.54	0.58	0.63	0.67	0.72	0.76	0.81	0.85	0.90	0.94	0.99	1.03	1.08
16	0.14	0.23	0.33	0.43	0.53	0.63	0.72	0.82	0.92	1.02	1.12	1.16	1.26	1.36	1.46	1.56	1.65	1.75	1.85	1.95	2.05	2.14	2.24	2.34
20	0.21	0.36	0.51	0.66	0.81	0.96	1.11	1.26	1.41	1.56	1.71	1.78	1.93	2.08	2.23	2.38	2.53	2.68	2.82	2.97	3.12	3.27	3.42	3.57
24	0.28	0.49	0.69	0.89	1.10	1.30	1.51	1.71	1.91	2.12	2.32	2.42	2.62	2.81	3.01	3.21	3.40	3.61	3.80	3.99	4.20	4.45	4.65	4.86
28	0.36	0.61	0.87	1.13	1.38	1.63	1.87	2.12	2.38	2.63	2.91	3.07	3.32	3.56	3.81	4.06	4.32	4.56	4.81	5.06	5.32	5.58	5.84	6.09
32	0.46	0.75	1.05	1.37	1.67	1.97	2.27	2.57	2.87	3.18	3.77	3.71	4.01	4.32	4.62	4.92	5.22	5.53	5.83	6.14	6.44	6.80	7.15	7.50
36	0.53	0.89	1.25	1.60	1.96	2.31	2.67	3.03	3.38	3.74	4.37	4.35	4.70	5.06	5.41	5.77	6.12	6.48	6.84	7.19	7.55	7.90	8.25	8.60
40	0.61	1.08	1.51	1.94	2.37	2.80	3.24	3.67	4.10	4.53	4.98	5.29	5.72	6.15	6.58	7.01	7.44	7.87	8.30	8.73	9.17	9.61	10.05	10.49
44	0.68	1.20	1.69	2.17	2.66	3.14	3.63	4.11	4.60	5.08	5.55	5.93	6.41	6.90	7.38	7.87	8.35	8.84	9.31	9.80	10.28	10.76	11.24	11.72
48	0.76	1.45	1.87	2.41	2.95	3.49	4.03	4.56	5.10	5.91	6.18	6.58	7.10	7.64	8.18	8.72	9.26	9.80	10.33	10.86	11.40	11.94	12.48	13.02
52	0.83	1.47	2.07	2.65	3.24	3.83	4.41	5.01	5.60	6.19	6.76	7.21	7.80	8.40	8.99	9.57	10.16	10.75	11.35	11.93	12.52	13.11	13.70	14.29
56	0.91	1.60	2.25	2.88	3.53	4.18	4.81	5.46	6.09	6.74	7.44	7.86	8.50	9.15	9.78	10.43	11.06	11.71	12.36	12.99	13.64	14.28	14.92	15.58
60	0.99	1.73	2.43	3.12	3.82	4.51	5.20	5.90	6.60	7.29	8.05	8.50	9.20	9.89	10.59	11.28	11.98	12.67	13.37	14.06	14.76	15.45	16.14	16.83
64	1.06	1.86	2.62	3.36	4.11	4.85	5.60	6.35	7.09	7.75	8.60	9.15	9.89	10.65	11.39	12.14	12.88	13.63	14.38	15.12	15.88	16.61	17.14	17.77
68	1.20	2.00	2.80	3.60	4.40	5.20	6.00	6.80	7.60	8.40	9.20	9.80	10.59	11.39	12.19	12.99	13.79	14.59	15.39	16.19	16.99	17.79	18.59	19.39
72	1.28	2.13	2.98	3.83	4.68	5.54	6.39	7.24	8.09	8.94	9.79	10.44	11.29	12.14	12.99	13.84	14.69	15.54	16.39	17.24	18.09	18.94	19.79	20.64
76	1.35	2.26	3.16	4.07	4.97	5.88	6.78	7.69	8.59	9.50	10.55	11.09	11.99	12.90	13.80	14.70	15.60	16.50	17.40	18.30	19.20	20.10	21.00	22.80
80	1.43	2.39	3.35	4.31	5.26	6.22	7.18	8.14	9.10	10.06	11.02	11.72	12.68	13.64	14.60	15.56	16.52	17.48	18.44	19.40	20.36	21.32	22.28	23.24
84	1.52	2.53	3.53	4.54	5.55	6.57	7.58	8.58	9.59	10.60	11.61	12.37	13.38	14.39	15.40	16.41	17.42	18.43	19.44	20.45	21.46	22.47	23.48	24.49
88	1.56	2.68	3.64	4.71	5.79	6.86	7.93	9.00	10.07	11.14	12.21	12.73	13.80	14.87	15.94	17.01	18.08	19.15	20.22	21.29	22.36	23.43	24.50	25.57
92	1.62	2.79	3.79	4.91	6.03	7.14	8.25	9.36	10.47	11.58	12.69	13.26	14.37	15.48	16.59	17.70	18.81	19.92	21.03	22.14	23.25	24.36	25.47	26.58
96	1.71	2.94	4.16	5.17	6.34	7.51	8.68	9.85	11.02	12.19	13.36	13.96	15.13	16.30	17.47	18.64	19.81	20.98	22.15	23.32	24.49	25.66	26.83	28.00
100	1.77	3.03	4.30	5.34	6.55	7.76	8.98	10.19	11.40	12.61	13.82	14.41	15.63	16.84	18.05	19.26	20.47	21.68	22.89	24.10	25.31	26.52	27.73	28.94
104	1.86	3.19	4.52	5.62	6.90	8.17	9.44	10.71	11.98	13.25	14.52	15.17	16.45	17.73	19.00	20.27	21.54	22.81	24.08	25.35	26.62	27.89	29.16	30.43

NOTE

See Table 1 on page 22 for the equivalent neck size (W x H).

SSL SERIES [SSL - 100, SSL - 110, SSL - 120]

Construction - Dimension and Details

- 1 - Casing
- 2 - Blade
- 3 - Bird Screen (optional)

SSL - 100, SSL - 110, SSL - 12 (Single Section)

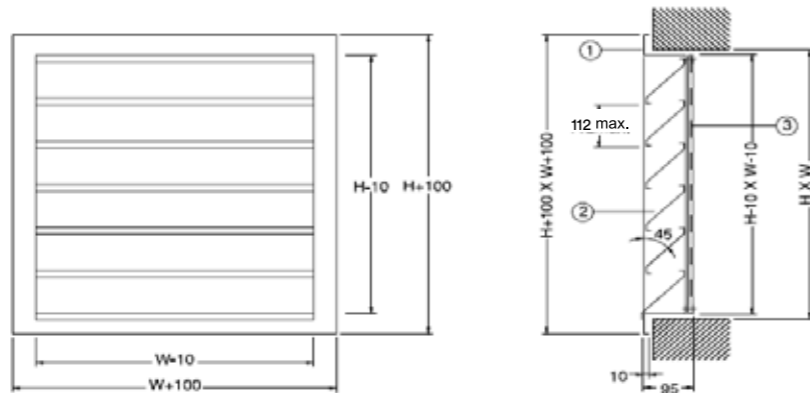

The maximum size for single section is up to 1250mm wide (W) and up to 2500mm height (H).

Single Module with Mullion

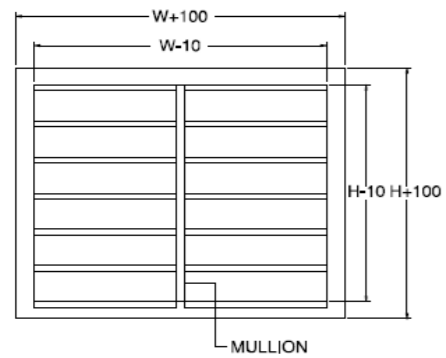

Single module with 2 sections on horizontal blades and with mullion from size above 1250mm up to 2500mm maximum width (W). The maximum Single Module is 2500 W x 2500 H.

Multiple Module (Segmented)

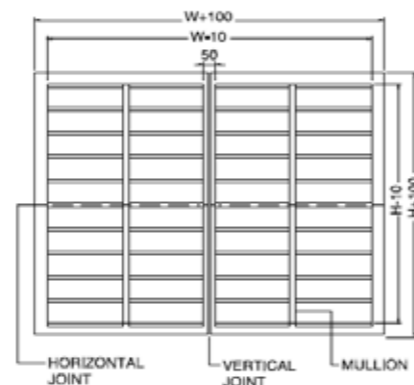

Segmented for size above 2500 W and 2500 H.

SSL SERIES [SSL - 100, SSL - 110, SSL - 120]

Multiple Module (Segmented) - Assembly Details

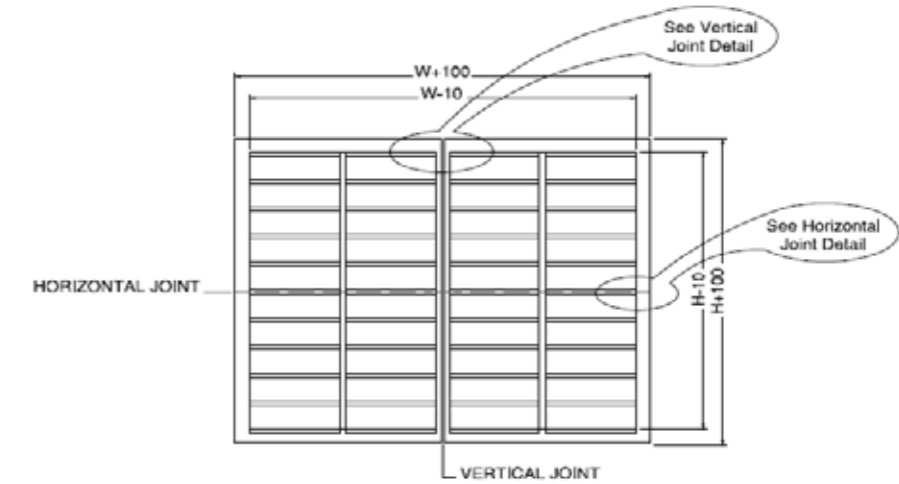

Vertical Joint Detail

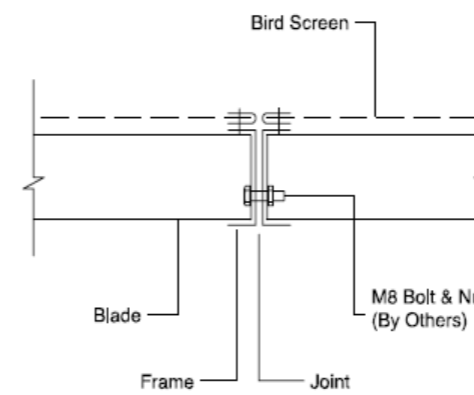

Horizontal Joint Detail

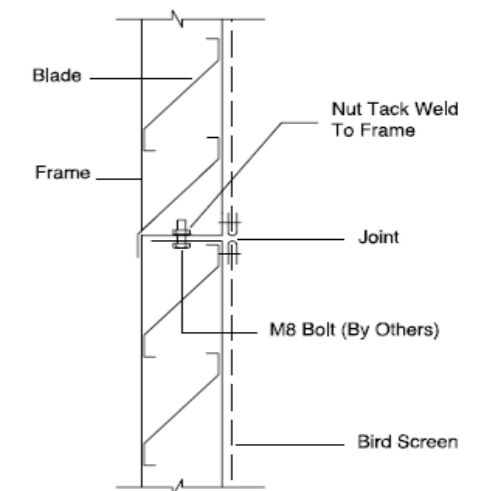



SSL SERIES [SSL - 100, SSL - 110, SSL - 120]

Table 1

Outer Frame Size (in.)	Neck Size (mm)
W1 x H1	W x H
12 x 12	200 x 200
16 x 16	300 x 300
20 x 20	400 x 400
24 x 24	500 x 500
28 x 28	600 x 600
32 x 32	700 x 700
36 x 36	800 x 800
40 x 40	900 x 900
44 x 44	1000 x 1000
48 x 48	1100 x 1100
52 x 52	1200 x 1200
56 x 56	1300 x 1300
60 x 60	1400 x 1400
64 x 64	1500 x 1500
68 x 68	1600 x 1600
72 x 72	1700 x 1700
76 x 76	1800 x 1800
80 x 80	1900 x 1900
84 x 84	2000 x 2000
88 x 88	2100 x 2100
92 x 92	2200 x 2200
96 x 96	2300 x 2300
100 x 100	2400 x 2400
104 x 104	2500 x 2500

Calculate for free area, neck size and pressure drop.

1. Free Area = 4000 CFM / 800 FPM = 5 square feet (ft<sup>2</sup>).
2. From Free Area Chart the outer frame size can be 48in. x 44in., or 64in. x 36in. (W1xH1).
3. From Table 1 neck size is 1100mm x 1000mm, or 1500mm x 800mm (WxH).
4. The pressure drop for Exhaust Air Louver from Exhaust Air Performance Graph at 800 feet per minute (FPM) is 0.12 in. W.G. (30Pa).
5. The pressure drop for Fresh Air Intake Louver from Intake Air Performance Graph at 800 feet per minute (FPM) is 0.105 in. W.G. (26Pa).

**NOTE**

For optional screens the pressure drop is additive and to be calculated separately.

Order Example

Product Code: SSL-100 - a - aaa x aaa

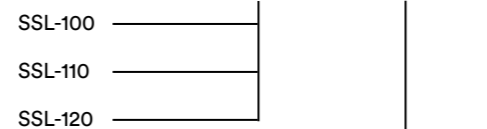

With Optional Extras:

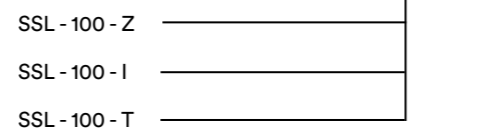

Sizes

**Standard**

**Make :** Airflow ac  
**Type :** SSL - 100 - 500 x 500

**With Optional Extras**

**Make :** Airflow ac  
**Type :** SSL - 100 - Z - 500 x 500

Selection Example

Selection Procedure of Stationary Louver

Example:

**With Given Air Volume:**  
Select Exhaust Air Louver or Fresh Air Intake Louver with a given air volume of 4000 cubic feet per minute (CFM) and 800 feet per minute (FPM) free area velocity.

Catalog ID: SSL - 100 January 26, 2014

SSL - 200

SSL SERIES EXTRUDED ALUMINUM



Description

SAFID Extruded Aluminum Stationary Louvers is designed to provide air intake and air exhaust openings in building exterior walls to protect against the direct ingress of rain. The blades are positioned on 104mm minimum centers up to 118mm maximum centers at 45 degree and has a high free area to provide minimum resistance to airflow.

Construction Standards

**Frame:**  
Extruded aluminum profile 2mm thick.

**Blades:**  
Extruded aluminum profile 1.8mm thick.

**Standard Finish:**  
Mill aluminum finish.

**Screen:**  
Expanded aluminum birdscreen.

**Minimum Size:**  
300 x 300 mm

**Maximum Size:**  
1200Wx2000H  
Larger sizes will be in multiple sections. For details of multiple sections consult SAFID.

Additional Options

- \*Code A: Anodized aluminum in silver.
- \*Code P: Polyester powder coated.
- \*Code Z: Painted to RAL (epoxy coated).
- \*Code I: Expanded aluminum insect screen.
- \*Code T: Bird screen in stainless steel, 5 x 5 x 0.7mm.

SSL - 210

General construction as type SSL - 200 but with drainable frame and blades. Drain gutter in each blades and downspouts in vertical frames allows water to drain from louver to minimize water cascade from blade to blade.

# STATIONARY LOUVER WITH EXTRUDED ALUMINUM PROFILES

## SSL SERIES [SSL - 200, SSL - 210]

### SSL - 200 ( Single Section )

1 - Frame      2 - Blades      3 - Bird Screen

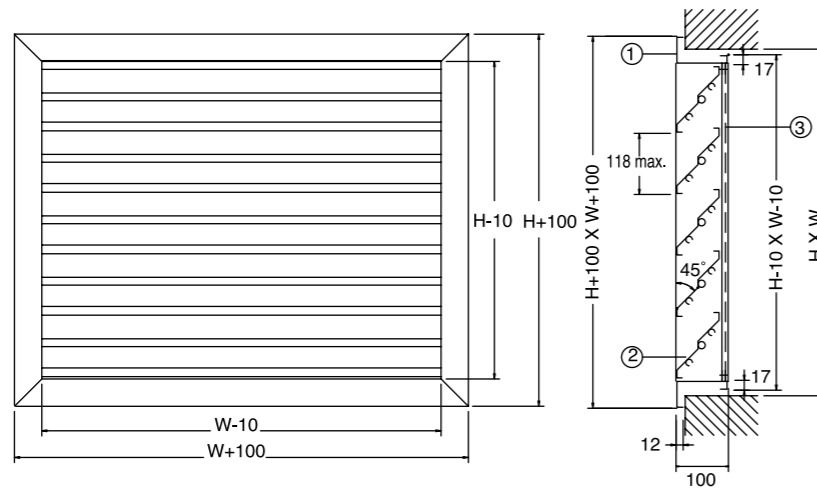

### SSL - 210 ( Single Section )

Legend:

1 - Drainable Frame      2 - Drainable Blades      3 - Bird Screen

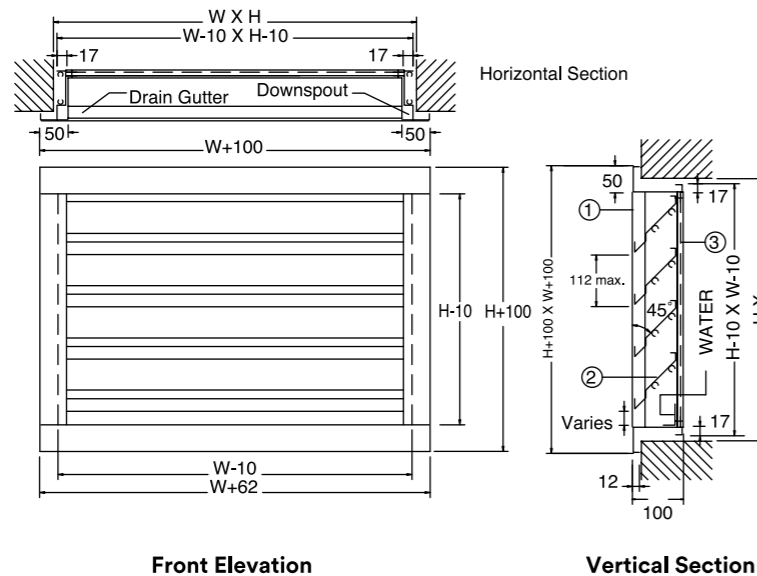

STATIONARY LOUVERS

# STATIONARY LOUVER WITH EXTRUDED ALUMINUM PROFILES

## SSL SERIES [SSL - 200, SSL - 210]

### Technical Data SSL - 200

#### Louver Selection and Application:

Application of stationary louver involves selecting velocity through free area that gives an acceptable pressure drop for intake and exhaust application.

#### Louver Free Area Chart:

H (m)	Width (meters)																					
	0.3	0.4	0.5	0.6	0.7	0.8	0.9	1	1.1	1.2	1.3	1.4	1.5	1.6	1.7	1.8	1.9	2	2.1	2.2		
0.3	0.013	0.018	0.024	0.029	0.035	0.040	0.046	0.051	0.057	0.062	0.064	0.070	0.075	0.081	0.087	0.092	0.098	0.103	0.109	0.114		
0.4	0.022	0.032	0.042	0.052	0.062	0.072	0.082	0.091	0.101	0.111	0.115	0.124	0.134	0.144	0.154	0.164	0.174	0.184	0.193	0.203		
0.5	0.030	0.044	0.057	0.071	0.084	0.098	0.111	0.125	0.138	0.152	0.156	0.170	0.183	0.196	0.210	0.223	0.237	0.250	0.264	0.277		
0.6	0.039	0.056	0.073	0.090	0.107	0.124	0.141	0.158	0.175	0.192	0.198	0.215	0.232	0.249	0.266	0.283	0.300	0.317	0.334	0.352		
0.7	0.047	0.067	0.088	0.109	0.129	0.150	0.171	0.191	0.212	0.233	0.240	0.260	0.281	0.302	0.322	0.343	0.364	0.384	0.405	0.426		
0.8	0.055	0.079	0.103	0.128	0.152	0.176	0.201	0.225	0.249	0.273	0.282	0.306	0.330	0.355	0.379	0.403	0.427	0.452	0.476	0.500		
0.9	0.063	0.091	0.119	0.147	0.175	0.203	0.230	0.258	0.286	0.314	0.324	0.352	0.379	0.407	0.435	0.463	0.49	0.519	0.547	0.575		
1	0.082	0.119	0.155	0.191	0.228	0.264	0.300	0.337	0.373	0.409	0.422	0.458	0.495	0.531	0.567	0.604	0.640	0.676	0.713	0.749		
1.1	0.091	0.132	0.172	0.213	0.253	0.293	0.334	0.374	0.415	0.455	0.469	0.509	0.549	0.590	0.630	0.671	0.711	0.751	0.792	0.832		
1.2	0.099	0.143	0.187	0.231	0.275	0.319	0.363	0.407	0.451	0.495	0.510	0.554	0.598	0.642	0.686	0.730	0.774	0.818	0.862	0.906		
1.3	0.107	0.155	0.203	0.250	0.298	0.345	0.393	0.440	0.488	0.536	0.552	0.599	0.647	0.694	0.742	0.789	0.837	0.885	0.932	0.980		
1.4	0.116	0.167	0.218	0.269	0.320	0.371	0.422	0.474	0.525	0.576	0.593	0.644	0.695	0.747	0.798	0.849	0.900	0.951	1.002	1.053		
1.5	0.124	0.178	0.233	0.288	0.343	0.397	0.452	0.507	0.562	0.616	0.635	0.690	0.744	0.799	0.854	0.909	0.963	1.018	1.073	1.127		
1.6	0.132	0.190	0.248	0.307	0.365	0.423	0.482	0.540	0.598	0.657	0.677	0.735	0.793	0.852	0.910	0.968	1.027	1.085	1.143	1.202		
1.7	0.140	0.202	0.264	0.326	0.388	0.450	0.512	0.574	0.635	0.697	0.718	0.780	0.842	0.904	0.966	1.028	1.090	1.152	1.214	1.276		
1.8	0.148	0.214	0.279	0.345	0.410	0.476	0.541	0.607	0.672	0.738	0.760	0.826	0.891	0.957	1.022	1.088	1.153	1.219	1.284	1.350		
1.9	0.156	0.225	0.295	0.364	0.433	0.502	0.571	0.640	0.709	0.778	0.802	0.871	0.940	1.009	1.079	1.14	1.217	1.286	1.355	1.424		
2	0.164	0.237	0.310	0.383	0.455	0.528	0.601	0.674	0.746	0.819	0.844	0.917	0.989	1.062	1.135	1.208	1.280	1.355	1.426	1.499		

#### Selection Procedure of Stationary Louver

##### Example:

##### With given air volume:

Select Fresh Air Intake Louver with a given air volume of 1.0m<sup>3</sup>/s and 3.5m/s free area velocity.

##### A - Determine Louver Free Area:

Dividing the given air volume (1.5m<sup>3</sup>/s) by free area velocity (3.5m/s, do not exceed to 4.2m/s for fresh air intake application), the free area will be:

$$\text{Louver Free Area} = \frac{1.5\text{m}^3/\text{s}}{3.5\text{m/s}} = 0.429 \text{ m}^2$$

##### B - Select a suitable louver from Free Area Chart

The following suitable louvers from Free Area Chart are:

1. 1m Wide x 1.3m High
2. 1.2m Wide x 1.1m High
3. 1.4m Wide x 1m High

##### C - Check the pressure drop of the selected louver on the Pressure Drop Chart:

The pressure drop across the selected size of louver is 25 Pa.

STATIONARY LOUVERS

**STATIONARY LOUVER WITH  
EXTRUDED ALUMINUM PROFILES**

SSL SERIES [SSL - 200, SSL - 210]

Technical Data SSL - 200

**Airflow Resistance**

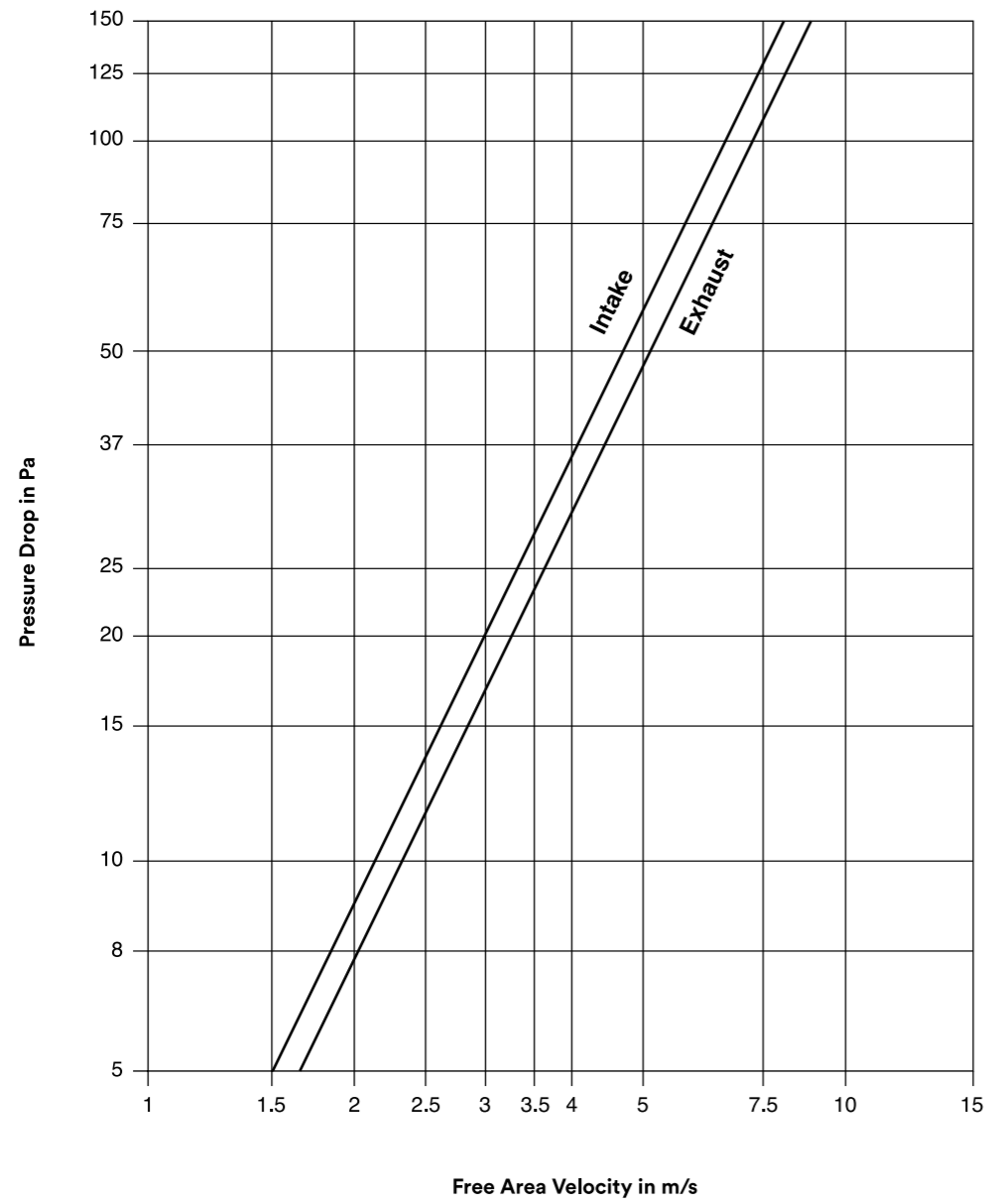

STATIONARY LOUVERS

**STATIONARY LOUVER WITH  
EXTRUDED ALUMINUM PROFILES**

SSL SERIES [SSL - 200, SSL - 210]

Technical Data SSL - 200

**Water Penetration**

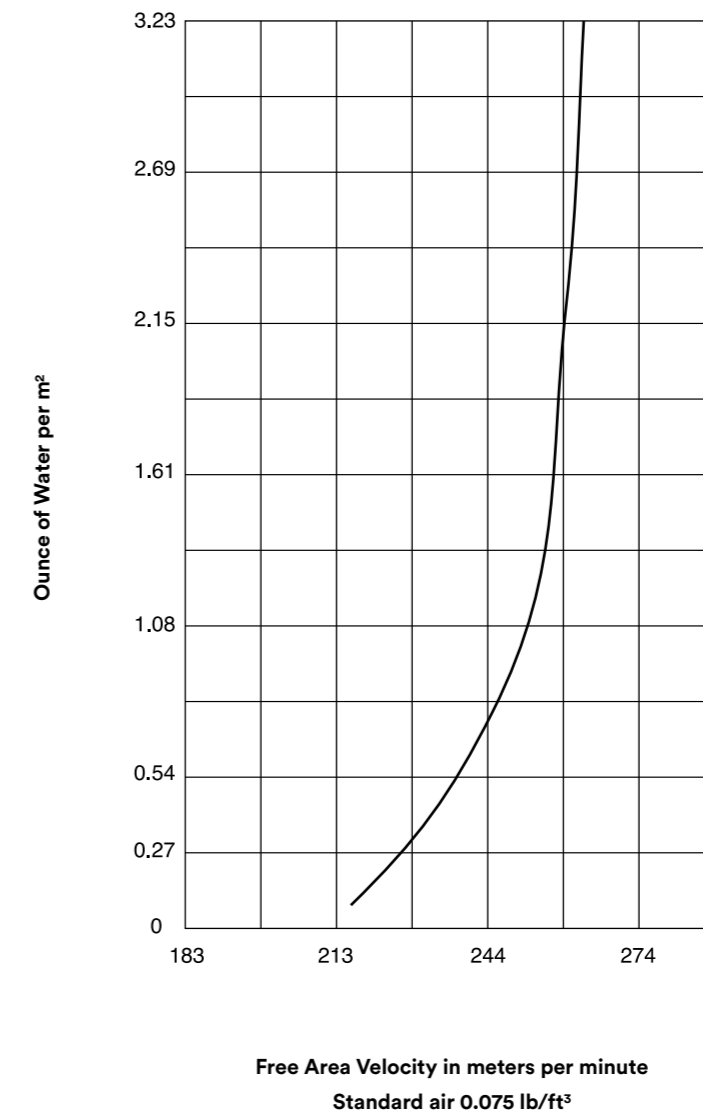

STATIONARY LOUVERS

# STATIONARY LOUVER WITH EXTRUDED ALUMINUM PROFILES

## SSL SERIES [SSL - 200, SSL - 210]

### Technical Data SSL - 210

#### Louver Selection and Application:

Application of stationary louver involves selecting velocity through free area that gives an acceptable pressure drop for intake and exhaust application.

#### Louver Free Area Chart:

H (m)	Width (meters)																			
	0.3	0.4	0.5	0.6	0.7	0.8	0.9	1	1.1	1.2	1.3	1.4	1.5	1.6	1.7	1.8	1.9	2	2.1	2.2
0.3	0.018	0.027	0.035	0.043	0.051	0.059	0.067	0.075	0.083	0.092	0.094	0.102	0.110	0.118	0.126	0.134	0.142	0.151	0.159	0.167
0.4	0.029	0.042	0.055	0.068	0.080	0.093	0.106	0.119	0.132	0.145	0.148	0.161	0.174	0.187	0.199	0.212	0.225	0.238	0.251	0.264
0.5	0.040	0.058	0.076	0.094	0.111	0.129	0.147	0.165	0.183	0.201	0.205	0.223	0.241	0.259	0.276	0.294	0.312	0.330	0.348	0.365
0.6	0.051	0.074	0.097	0.120	0.143	0.165	0.188	0.211	0.234	0.257	0.262	0.285	0.308	0.331	0.354	0.376	0.399	0.422	0.445	0.468
0.7	0.063	0.091	0.118	0.146	0.174	0.202	0.229	0.257	0.285	0.313	0.320	0.348	0.375	0.403	0.431	0.459	0.486	0.514	0.542	0.570
0.8	0.074	0.107	0.140	0.172	0.205	0.238	0.271	0.303	0.336	0.369	0.377	0.410	0.443	0.476	0.508	0.541	0.574	0.607	0.639	0.672
0.9	0.085	0.123	0.161	0.199	0.236	0.274	0.312	0.350	0.387	0.425	0.435	0.473	0.510	0.548	0.586	0.624	0.661	0.699	0.737	0.775
1	0.097	0.139	0.182	0.225	0.268	0.310	0.353	0.396	0.438	0.481	0.492	0.535	0.578	0.620	0.663	0.706	0.749	0.791	0.834	0.877
1.1	0.108	0.156	0.203	0.251	0.299	0.346	0.394	0.442	0.490	0.537	0.550	0.598	0.645	0.693	0.741	0.788	0.836	0.884	0.932	0.979
1.2	0.119	0.172	0.225	0.277	0.330	0.383	0.435	0.488	0.541	0.594	0.607	0.660	0.713	0.765	0.818	0.871	0.924	0.976	1.029	1.082
1.3	0.130	0.188	0.246	0.304	0.361	0.419	0.477	0.534	0.592	0.650	0.665	0.723	0.780	0.838	0.896	0.953	1.011	1.069	1.126	1.184
1.4	0.142	0.204	0.267	0.330	0.393	0.455	0.518	0.581	0.643	0.706	0.722	0.785	0.848	0.910	0.973	1.036	1.099	1.161	1.224	1.287
1.5	0.153	0.221	0.288	0.356	0.424	0.491	0.559	0.627	0.695	0.762	0.780	0.848	0.915	0.983	1.05	1.118	1.186	1.254	1.321	1.389
1.6	0.164	0.237	0.310	0.382	0.455	0.528	0.600	0.673	0.746	0.818	0.837	0.910	0.983	1.055	1.128	1.201	1.273	1.346	1.419	1.491
1.7	0.175	0.253	0.331	0.408	0.486	0.563	0.641	0.719	0.796	0.874	0.894	0.972	1.049	1.127	1.204	1.282	1.360	1.437	1.515	1.592
1.8	0.186	0.269	0.352	0.434	0.517	0.599	0.682	0.764	0.847	0.929	0.951	1.033	1.116	1.198	1.281	1.363	1.446	1.528	1.611	1.693
1.9	0.198	0.285	0.373	0.460	0.547	0.635	0.722	0.810	0.897	0.985	1.007	1.095	1.182	1.270	1.357	1.445	1.532	1.620	1.707	1.794
2	0.209	0.301	0.394	0.486	0.578	0.671	0.763	0.855	0.948	1.040	1.064	1.157	1.249	1.341	1.434	1.526	1.618	1.711	1.803	1.896

#### Selection Procedure of Stationary Louver

##### Example:

##### With given air volume:

Select Fresh Air Intake Louver with a given air volume of 1.5m<sup>3</sup>/s and 3.5m/s free area velocity.

##### A - Determine Louver Free Area:

Dividing the given air volume (1.5m<sup>3</sup>/s) by free area velocity (3.5m/s, do not exceed to 4.2m/s for fresh air intake application), the free area will be:

$$\text{Louver Free Area} = \frac{1.5\text{m}^3/\text{s}}{3.5\text{m/s}} = 0.429\text{ m}^2$$

##### B - Select a suitable louver from Free Area Chart

The following suitable louvers from Free Area Chart are:

1. 1.1m Wide x 1.0m High
2. 1.3m Wide x 0.9m High
3. 1.5m Wide x 0.8m High

##### C - Check the pressure drop of the selected louver on the Pressure Drop Chart:

The pressure drop across the selected size of louver is 34 Pa.

# STATIONARY LOUVER WITH EXTRUDED ALUMINUM PROFILES

## SSL SERIES [SSL - 200, SSL - 210]

### Technical Data SSL - 210

#### Airflow Resistance

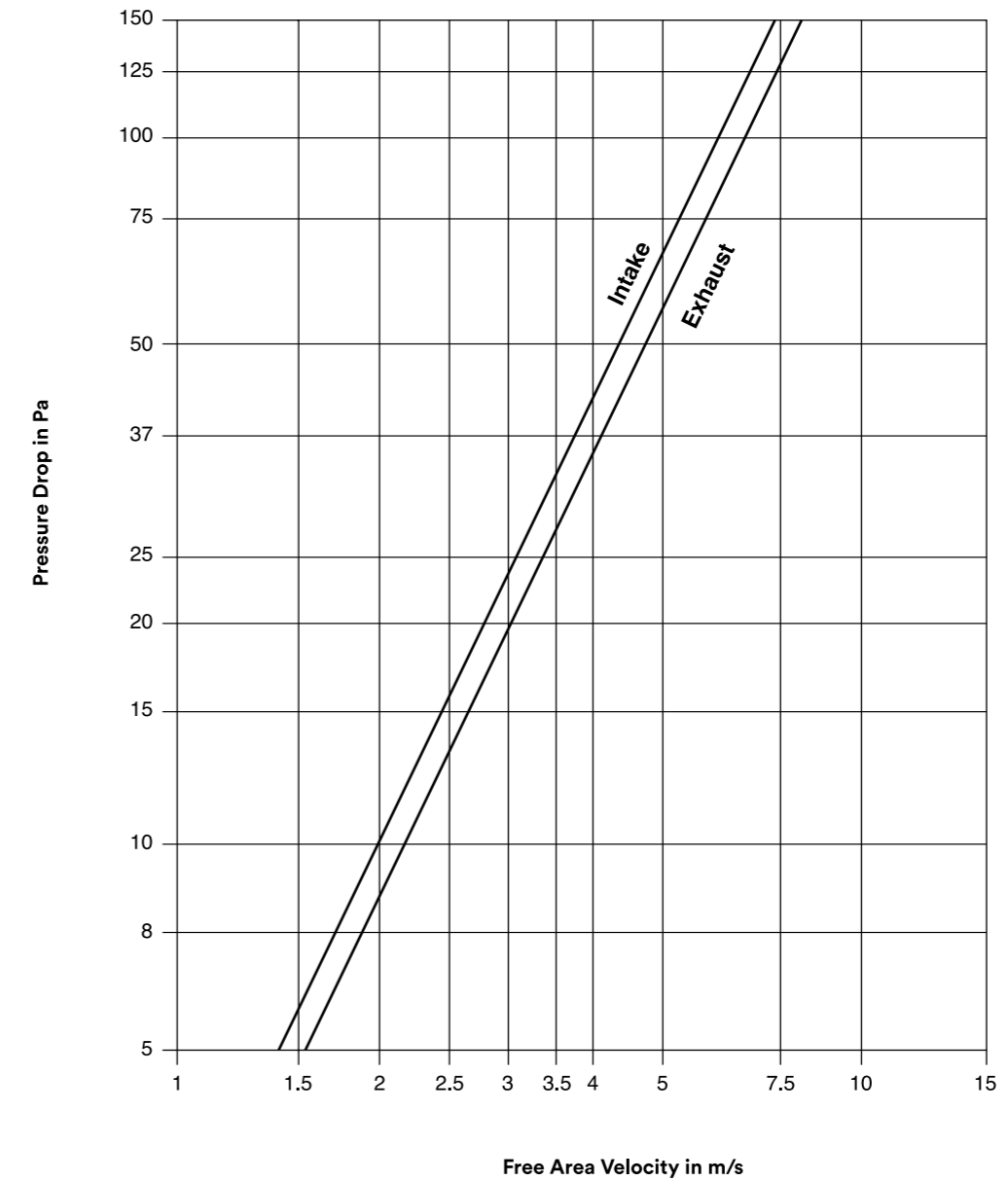



# STATIONARY LOUVER WITH EXTRUDED ALUMINUM PROFILES

SSL SERIES [SSL - 200, SSL - 210]

Technical Data SSL - 210

## Water Penetration

