

Engineered Products



Volume control Damper Type MBD



Airflow AC Middle East FZE-LLC

Email:- airflowacme@gmail.com, www.airflowac.me

Blade Features

Application

The MBD range of dampers are suitable for air conditioning and ventilation systems requiring air control and low closed blade leakage performance.

Blade construction for system pressures up to 1000Pa and duct velocities of up to 10m/s on the MBD35 and MBD35-1 range and 1500Pa, and 20m/s on the MBD50 range.

Suitable for applications in normal dry filtered air systems, including modulation function. If exposed to fresh air intakes, and/or inclement conditions, the 316 stainless steel option should be considered by the client (MBD35 & 35-1).

All installations should be subject to a planned inspection programme, frequency of which is dependant upon application and environmental conditions.

For specialist applications and products outside specified parameters, please consult with our Technical Sales Office.

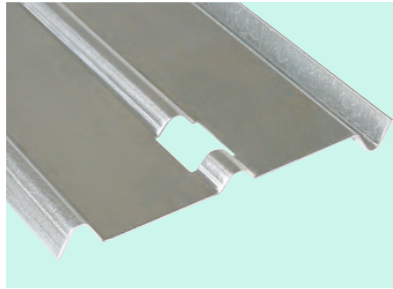

MBD35

1.5mm thick triple "Vee" groove blade profile, to give maximum strength.
Suitable for systems with an operational temperature range of -40°C to +70°C.
Standard: Galvanised steel.
Optional: 316 stainless steel.

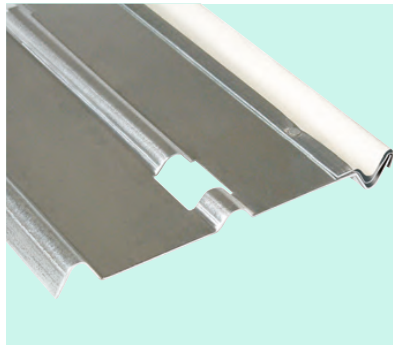

MBD35-1

1.5mm thick triple "Vee" groove blade profile, to give maximum strength. With additional blade seals attached within blade "Vee" groove to create low closed blade leakage.
Suitable for systems with an operational temperature range of 180°C. continuous operation.
Standard: Galvanised steel.
Optional: 316 Stainless steel.

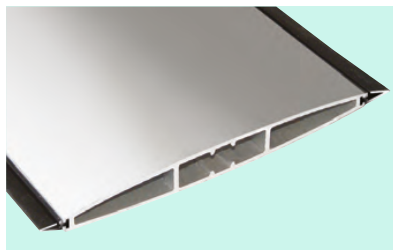

MBD50

Profiled aerodynamic aluminium extrusion for low noise generation. Blade tip seals to give very low closed blade leakage.
Suitable for systems with an operational temperature range of -40°C to +70°C (+70°C only standard blade seal).

Casing and Drive Features

All damper blades are within the casing i.e. they do not protrude beyond the casing depth. This ensures blades will not foul equipment (such as grilles or louvres) that may be fitted adjacent to the damper. This feature also allows easy fitting and removal of the Flanged damper. The 165mm wide Flanged casing consists of a single skin 1.2mm steel frame with 40mm flanges and pre-punched corner holes to suit proprietary duct flanges. The Spigot (MBD) type casings are 178mm wide that include spigotted end caps fitted to either side of the Flange casing.

Total depth over spigots
Type MBD(square/rectangular) = 254mm
Type MBD (circular) and flat oval (ov) = 304mm

For all MBD50 Dampers, the damper casing leakage conforms to HVCA Ductwork Specification DW144 class A,B and class C. Optional DW144 class C leakage available. Requires additional side cover plates.

301 grade stainless steel side gasketting is fitted as standard to series MBD35-1, and

MBD50 which significantly reduces air leakage between the blade ends, and the internal sides of the damper casing.

Blade Drive Mechanism

The blade drive mechanism is mounted out of the airstream to minimise pressure and noise generation, blade axles are 11.1mm hexagonal zinc plated steel. Synthetic blade bearings give a corrosion resistant, hard wearing and free running operation.

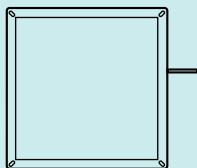

Type MBD-F
Square/Rectangular

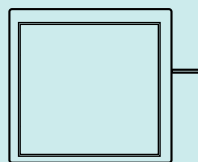

Type MBD
Square/Rectangular

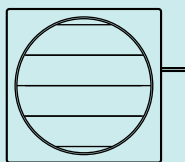

Type MBD-R Circular



Type MBD-OV Flat Oval

Size Range

Type MBD-F and Type MBD (Rectangular)

Single section

Widths in any size from 100mm to 1200mm.

Heights in any height from 100mm to 1800mm (MBD: 1700mm) in increments of 1mm.

Double section

1. Single drive with hexagon coupling

Widths in any size from 1201mm to 2080mm.

Heights in any height from 200mm to 1800mm (MBD: 1700mm) in increments of 1mm (MBD35).

Heights in any height from 200mm to 1000mm in increments of 1mm (MBD35-1/MBD50).

2. Single Drive with jackshaft

Widths in any size from 1201mm to 2480mm.

Heights in any height from 350mm to 1800mm in increments of 1mm.

3. Drive both sides

Widths in any size from 1201mm to 2480mm.

Heights in any height from 200mm to 1800mm (MBD: 1700mm) in increments of 1mm.

Type CIRCULAR

Diameters in any size from 200mm to 1000mm.

Type Flat Oval

Single section

Widths in any size from 300mm to 1200mm.

Double section

Widths in any size from 1201mm to 2000mm.

Single or double section

Heights in any size from 200mm to 550mm.

Double section arrangement

Heights up to and including 1000mm, supplied factory assembled

Heights above 1000mm, supplied individually with joining strips for site assembly, by others.

Additional note for multiple Type MBD (Rectangular)

Spigots attached to individual single section dampers. On-site provision of filling gaps between spigot and duct where dampers join required by others.

Dimensions

Flanged Casing (Type MBD-F). Single Drive (no mullion)

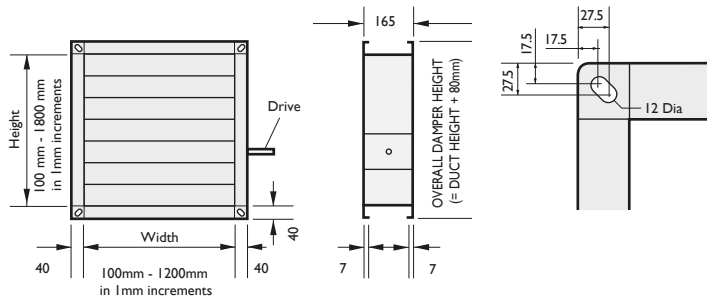

Spigot Casing (Type MBD Rectangular)
MBD rectangular spigots are supplied 5mm under duct size.

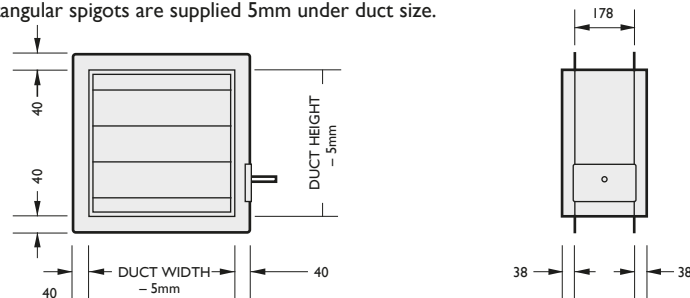

Spigot Casing (Type MBD Circular)
MBD circular spigots are supplied 3mm under duct size.

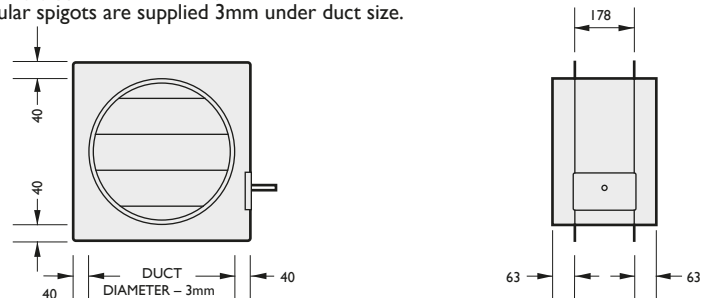

Spigot Casing (Type MBD Flat Oval)
MBD flat oval spigots are supplied 3mm under duct size.

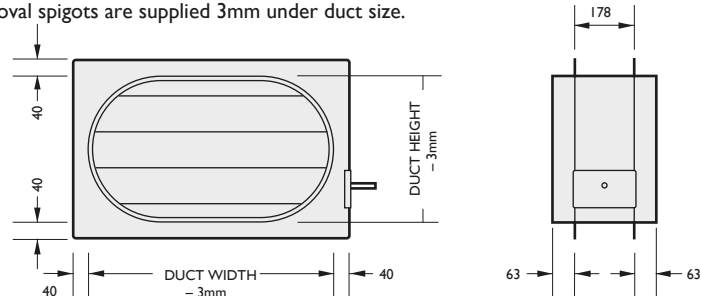

Alternative casing depths (MBD) in mm

- 100, 120, 150, 160
Blades will protrude outside casing.
- 165 default standard.
- 175, 200, 250.
- Note: 100 and 120 not available with side covers or jack shaft.

Control Options

Extended Shaft Control (Option X)

12.7mm diameter Zinc plated steel Extended Spindle for motorised control. Supplied as standard, loose for site fitting by others.

MBD-F Type Casing

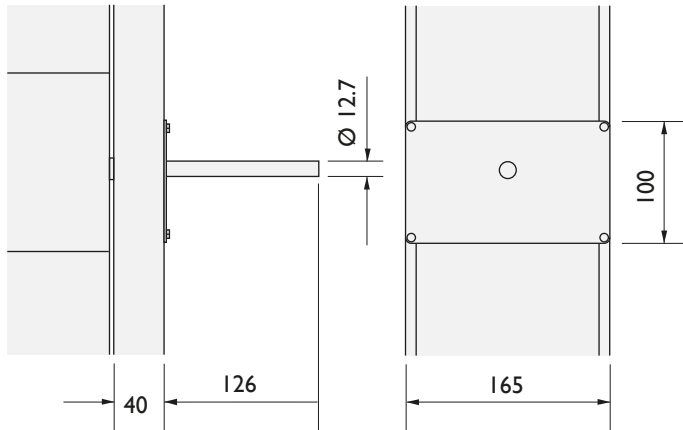

MBD Type Casing

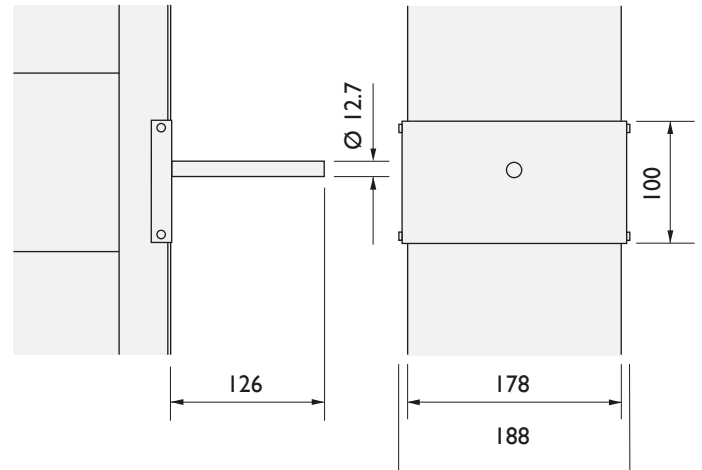

Casing Leakage Options

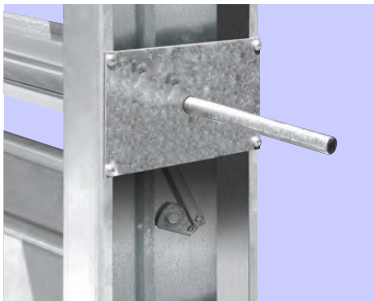

Exposed Linkage Class 'B' Casing leakage.

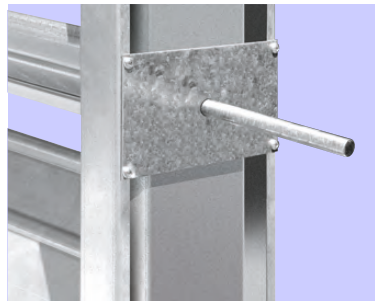

Side covers for Class 'C' Casing leakage. Class 'C' Casings have spindle factory fitted.

Note:
Class 'C' casings
have spindle
factory fitted.

Manual Quadrant Control (Option HLQ)

Manual Quadrant Control, fits onto a reduced shaft control. Supplied loose for site fixing by others.



Class 'C' Casings have spindle factory fitted.

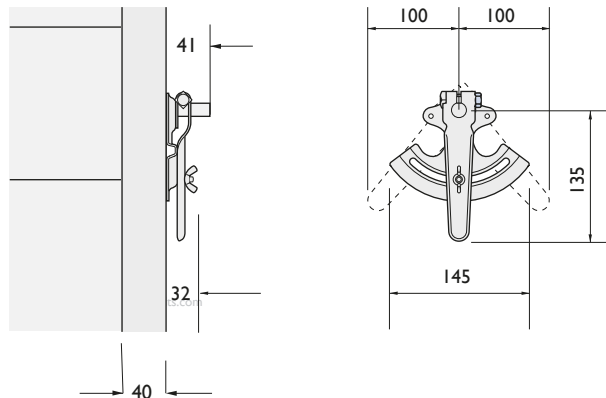

Technical Data

Pressure Drop Vs Velocity at intermediate Blade positions .
 Dampers tested were 600mm x 600mm square

MBD-FO (Opposed Blade)

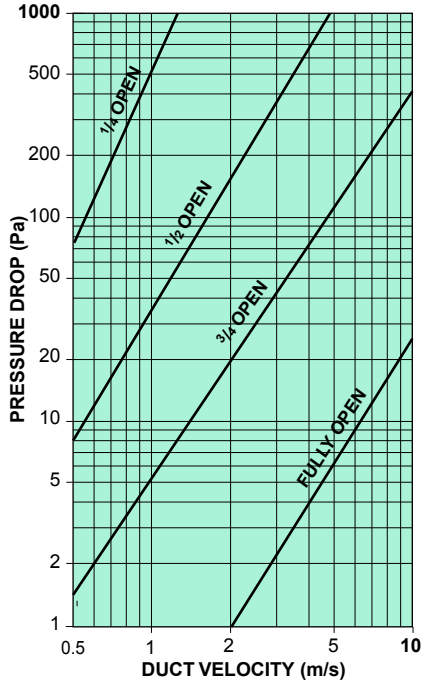

MBD-FP (Parallel Blade)

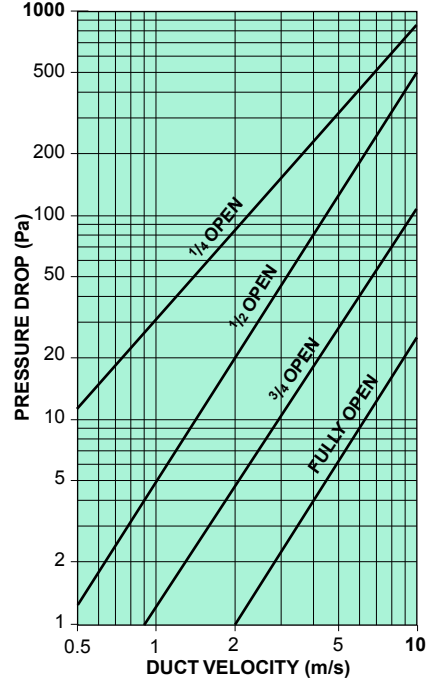

MBD-50 (Opposed Blade)

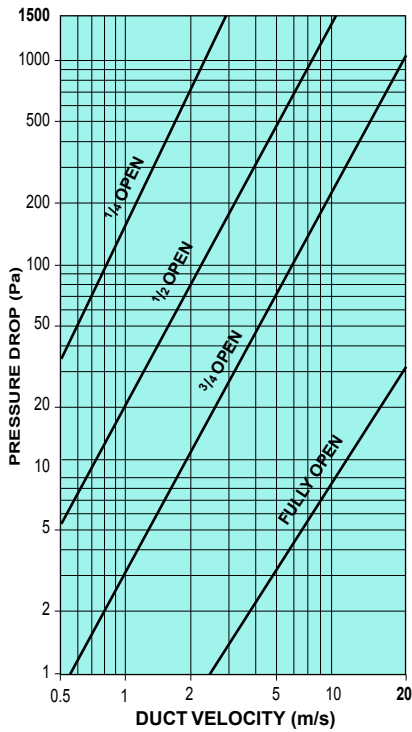

MBD-50 (Parallel Blade)

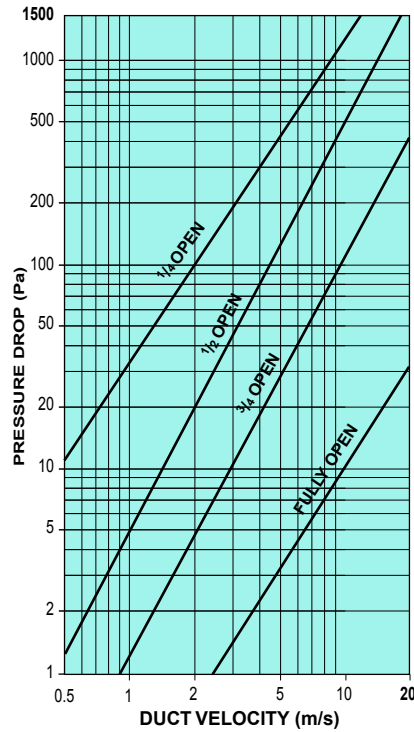

Technical Data

Damper Leakage

MBD-35 Closed Blade leakage
1000mm wide x 1000mm high damper

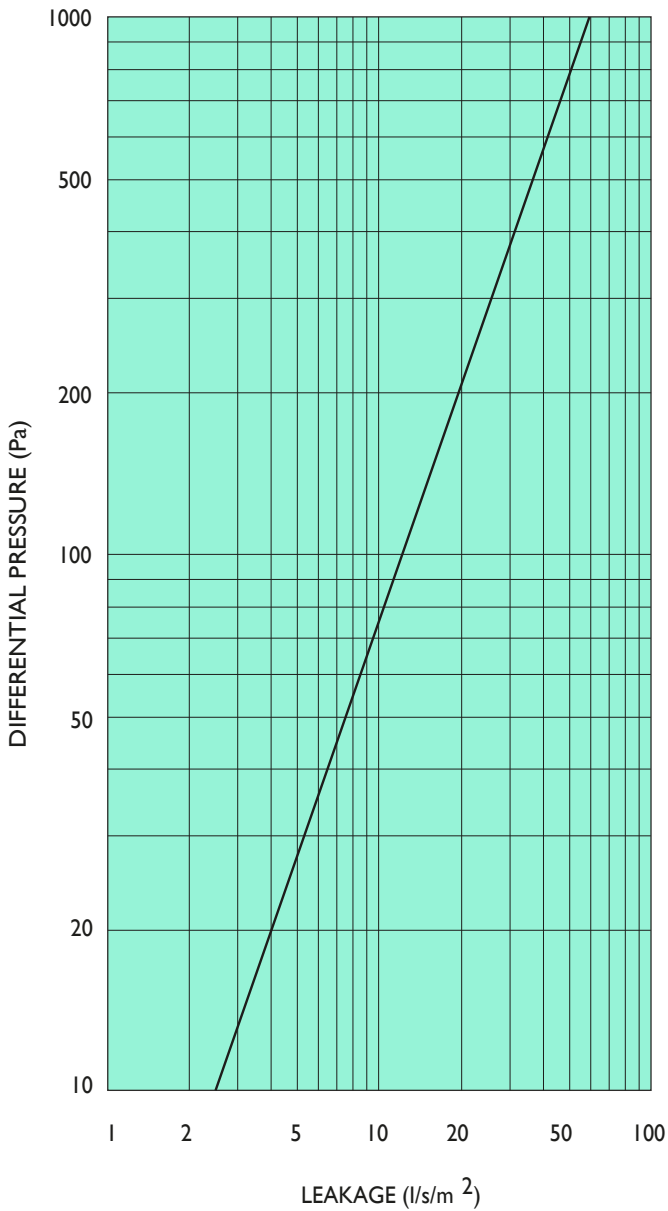

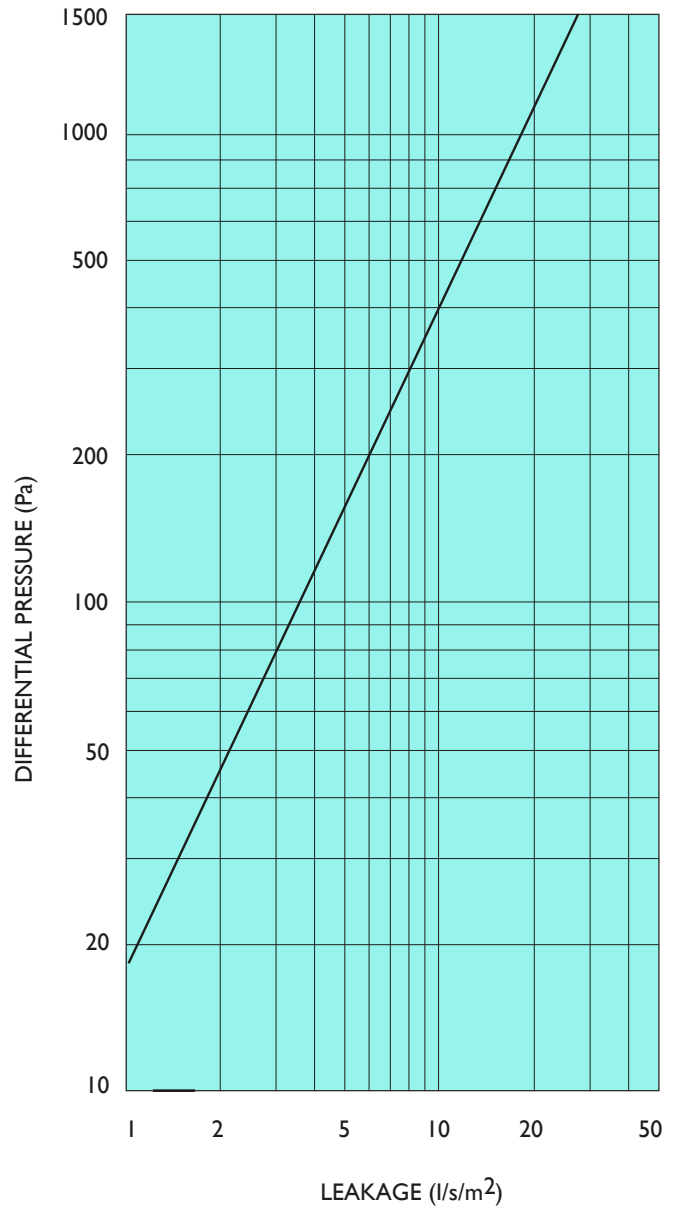

MBD-50 Closed Blade leakage
1000mm wide x 1000mm high damper

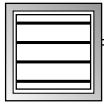
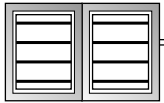

Selection

Electrical Controls

Single Section	Double Section	Dia mm	Open/close or Modulating				Spring return	
			5 Nm LM-A	10 Nm NM-A	20 Nm SM-A	40 Nm GM-A	4 Nm LF	15 Nm AF
								
RECTANGULAR/OVAL		CIRCULAR						
MBD35								
Up to 0.26 M ²		Up to 500mm Dia	●				●	
Up to 0.43 M ²		Up to 650mm Dia	●					●
Up to 0.96 M ²		Up to 950mm Dia		●				●
Up to 1.35 M ²		Above 950 mm Dia		●				●
Above 1.35 M ²					●			●
	Up to 0.44 M ²			●				●
	Up to 0.72 M ²			●				●
	Up to 1.58 M ²				●			●
	Up to 1.76 M ²				●			
	Up to 2.46 M ²				●			
	Above 2.46 M ²					●		
MBD35-1/50								
Up to 0.11 M ²		Up to 300mm Dia	●				●	
Up to 0.18 M ²		Up to 400mm Dia	●					●
Up to 0.44 M ²		Up to 650mm Dia		●				●
Up to 0.79 M ²		Up to 850mm Dia		●				●
Up to 1.62M ²		Above 850mm Dia			●			●
Up to 1.79 M ²					●			
Above 1.79M ²					●			
	Up to 0.36M ²			●				●
	Up to 0.64 M ²				●			●
	Up to 0.72 M ²				●			
	Up to 1.36 M ²				●			
	Above 1.36 M ²					●		